

1. SCOPE

This specification is applied to the ceramics resonator used for the clock Oscillation of Microprocessor.

2. MODEL NAME

Part Name	Customer' s Part number	Drawing No.
ZTA33.86MX		
ZTT33.86MX		

3. DIMENSIONS

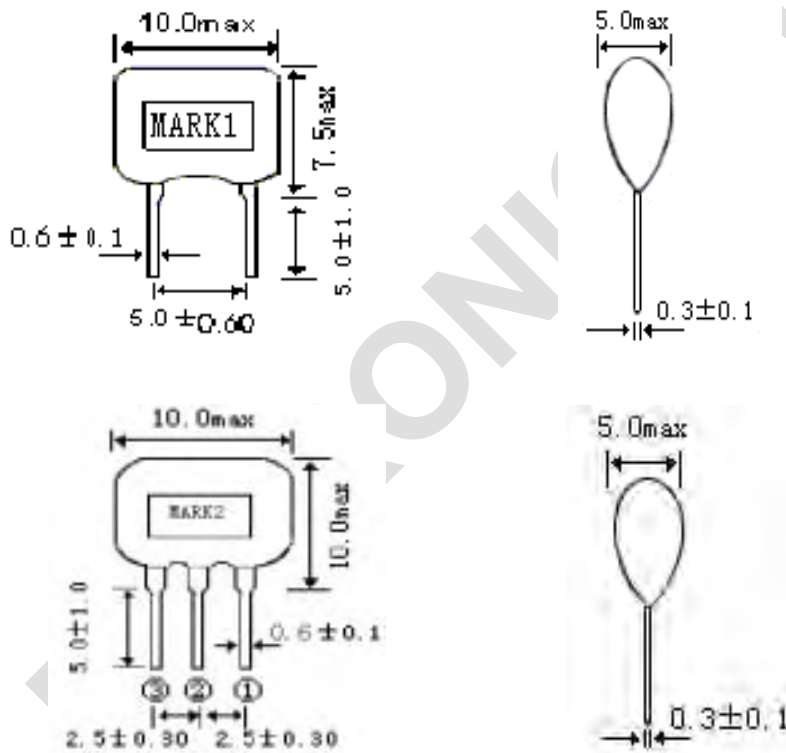

MARK 1: ZTA33.86MX

MARK 2: ZTT33.86MX

## 4. TEST CIRCUIT

Parts shall be measured under a condition (Temp.:3~35°C.Hum.:45~85%) unless any Necessity to measure under a standard condition (Temp.:20±2°C.Humi.:65±5%) is occurred.

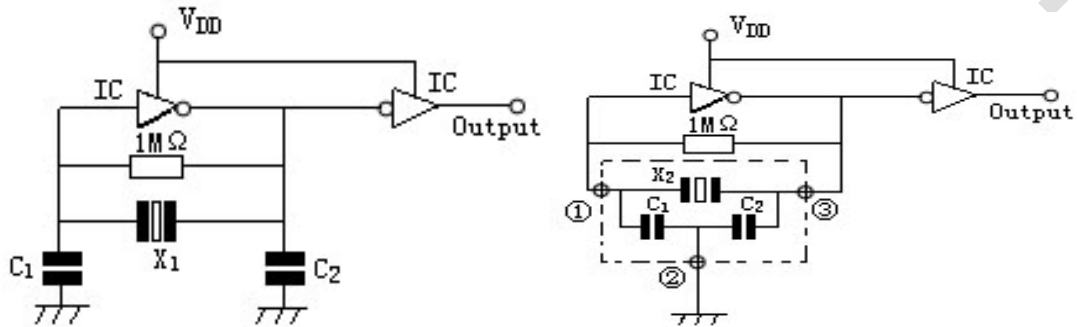

X1: ZTA33.86MX

X2: ZTT33.86MX

C1=C2=5PF

IC: 1/674HCU04

VDD=+5V

## 5. ELECTRICAL CHARACTERISTICS

	Item	Requirements
5-1	Frequency Accuracy	33.86M±0.5%
5-2	Resonant Impedance	35 Ω max
5-3	Operating Temperature Range	-20 to +80
	Storage Temperature Range	-30 to +85
5-4	Stability Temperature	±0.3% max. (-20—+80℃)
5-5	Withstanding Voltage	DC 100V. (less than 5 sec)
5-6	Insulation Resistance	100 MΩ min (DC 10V)
5-7	Aging for 10 Years	±0.5±% max

## 6. PHYSICAL AND ENVIRONMENTAL CHARACTERISTICS

	Test Item	Condition of Test	Requirements
6-1	Lead strength  Lead Bending	Force of 1 Kg is applied for 10 second to each lead in axial direction.  Firmed the terminal up to 2mm. Resonator lead shall be subjected to withstand against 90° bending its stem. This operation shall be done toward both directions.	No mechanical damage and the measured values shall meet Item5.
6-2	Solder ability	The terminals of the Resonator shall be immersion in a soldering bath (230±5℃) for 3±0.5sec. (refer to Mil-STD-202E-208C)	The solder shall for coat at least 95% of the terminal.
6-3	Vibration	Resonator shall be measured after being Applied vibration as below. Vibration Freq: 10-55Hz Amplitude: 1.5 mm Directions: 3 axial directions Time: 2 hour/each direction	The measured values Shall meet table 1
6-4	Random Drop	Resonator shall be measured after 3 times Random dropping from the height of 1m. Concrete floor	
6-5	Resistance to Soldering Heat	Dipped in (350±10℃) measured solder to a point 1.5mm from Resonator body for 3±0.5 sec or dipped in (260±5℃) melted solder for 10±1 sec. Resonator shall be measured after being placed in natural condition for 1 hour.	

## 6. PHYSICAL AND ENVIRONMENTAL CHARACTERISTICS

	Test Item	Condition of Test	Requirements
6-6	Humidity	After being placed in a chamber (Humi: 90-95%RH Temp:40±2 °C ) for 96 hours Resonator shall be measured after placed in natural condition for 1 hour.	The measured values Shall meet table 1
6-7	Life Test (High temperature)	After being placed in a chamber 85±2°C for 96 hours, Resonator shall be measured after being placed in natural condition for 1 hour.	
6-8	Life Test (Low temperature)	Stored in a chamber (Temp:-20±2°C) for 1000 hours, Resonator shall be measured after being placed in natural condition for 1 hour.	
6-9	Thermal shock	After temperature cycling of -20°C (30 min) to +80°C (30min) was performed 5 times the Resonator shall be measured after being placed in natural condition for 1 hour.	

Table 1

Item	Limit Value
Frequency shift	$F/FO \leq \pm 0.3\%$
Resonant Impedance	$Z_r \leq 5 \Omega$

Note: The limits in the above table are referenced to the initial Measurements.

**7. NOTICE**

- 7.1 Ceramic Resonator should be stored in storeroom. And the surrounding atmosphere is acid less, alkali-free and no other harmful impurity.**
- 7.2 The package for ceramic damage.**
- 7.3 This specification limits the quality of the component as a single unit.  
Please make sure that the component is evaluated and confirmed the drawing  
When it is mounted to your product.**